

Mapleshade School

Handbook



**175 Mapleshade Avenue
East Longmeadow, MA 01028
(413) 525-5485 – Main Office
(413) 525-5488 – School Nurse**

www.eastlongmeadowma.gov

2019-2020

Table of Contents

Principal's Message.....	3
Philosophy - Vision.....	4
PTO - School Councils.....	5
School Calendar	6
Student Records.....	6
Parent-Teacher Conferences.....	6
School Pictures.....	6
Lost and Found.....	6
Student Drop-off and Pick-up.....	7,8
Safety and Transportation.....	9
School Cancellation/Delayed Openings.....	10
School Visitations.....	10
Student Absences/Early Dismissal.....	10
School Lunches and snacks	11
Pupil Conduct.....	12
Homework Policy.....	13
Progress Reporting.....	14
Insurance/Student Information.....	14
Special Services.....	14
Health Policies.....	15
School Website.....	16
Parent/Guardian Information Sharing.....	16
Communicating concerns.....	16

Curriculum and Academics.....	17 - 18
Student Assessments.....	18
Assisting Children and Teacher Team.....	18
Code of Conduct reference.....	19

PRINCIPAL'S MESSAGE

Dear Mapleshade Students and Families:

I would like to welcome every family to a new school year! Many teachers have embarked upon new learning through various professional development opportunities, conferences, workshops, and studies that they are eager to utilize and improve your child’s educational experience. Our maintenance staff and departments have been working diligently to ensure a clean, neat and organized learning environment for the beginning of the school year. Lastly our IT department has been ensuring that we are technologically ready to begin the school year and meet the demands of the future. We will continue to ensure that your school is a welcoming place that meets the needs of all children and is committed to student’s academic, social and physical growth.

This handbook is filled with important information. Please read both the handbook and the Code of Conduct with your child, talk about the information, and feel free to call us or ask a staff member if you need an explanation or clarification. What is inside the handbook and the Code of Conduct reflects the routines and expectations for children in our school. A safe learning environment needs to follow consistent and clear rules and routines. When children understand the expectations of the school and know that their parents support them, the school year will go smoothly and all of the children will feel happy and safe.

Lastly, we invite you to be an active participant in the Mapleshade community! There will be opportunities through PTO, field trips, Field Day, parent-child events, etc. to volunteer and be part of your child’s school. Let us work together to embark upon your child’s educational journey in a school where people like to come and children love to learn.

Sincerely,

Michael R. Fredette, Principal

PHILOSOPHY - VISION

PHILOSOPHY

The purpose of our statement of educational philosophy is to articulate clearly the overall beliefs of our school system and school to the community. The school system has two roles: 1) to reflect the values and to respond to the needs and desires of the community and 2) to challenge the students to greater accomplishments and aspirations.

A basic underlying theme of our educational system is that everyone (students, staff and community) can learn from one another. The understanding of and the respect for the diversity of ethnic, cultural, intellectual and physical differences permeate all aspects of the school system.

Professional staff recognizes and responds to the intellectual capacity and learning style of each individual student. Individuals grow intellectually at different rates and in different ways. A complete education exposes all students to a wide range of learning opportunities.

Learning is viewed as the primary focus of each student's experience. Students are provided opportunities to continually develop their intellectual, physical, social and emotional potential. It is recognized that the student's self-esteem is of paramount importance in this process. Opportunities for development are nurtured in all learning situations. In order to maximize the attainment of these goals, student-centered experiences are provided by all staff.

In keeping with the desire to place the student at the center of learning, the teacher will be viewed as facilitator and coach. All staff will establish an appropriate learning environment and provide feedback to allow each student the opportunity to master appropriate academic, social and emotional skills for which the student is ready.

Mapleshade is committed to educational excellence. Teachers are at the center of this process and are supported in their efforts to provide their students with a quality education.

VISION

We believe in creating a respectful and challenging learning environment that cultivates interpersonal communication skills, collaboration, encouragement, and engagement for the entire Mapleshade community.

In keeping with this mission, we provide our educators with the following guidelines to serve as the template for the learning environment.

- A. Learning occurs when teacher's expectations are that all students can be successful and that all students can learn.
- B. Learning is best facilitated by instructors who have a command of content knowledge as well as awareness of the individual student's abilities and learning style.
- C. Learning is characterized by active, engaged, collaborative and integrated exploration with the student at the center of all activities.
- D. Learning optimally occurs through interactive and cooperative experiences among teachers, students, parents and the community.
- E. Learning reflects a focus on thinking, reasoning and higher order questioning as well as the understanding of the learner's own thinking processes.
- F. Learning is driven by a search for meaningful answers or alternative solutions to problems. Learning is maximized when the student's work is thought-provoking and when content is viewed as a means to a larger end.

PTO

The Mapleshade PTO is dedicated to enriching the educational experience of every child at Mapleshade School through a variety of activities. All parents are automatically members and are invited to actively join in. Yearly fundraisers allow the PTO to fund enrichment programs, field trips and to purchase school equipment. The PTO also runs annual book fairs, a Jog-A-Long, a Family Night, and a Teacher Appreciation Week. Our scheduled meetings keep parents informed of school and system related matters. Remember, we are working for our children. Your ideas are welcomed and your participation is appreciated.

SCHOOL COUNCILS (Chapter 71, Section 59C:)

At each public elementary school in the Commonwealth there shall be a school council consisting of the school principal, who shall co-chair the council; parents of students attending the school, who shall be selected by the parents of students attending such school, who will be chosen in elections held by the local recognized Parent Teacher Organization under the direction of the principal. Said parents shall have parity with professional personnel on the school councils; teachers who shall be selected by the teachers in such school; other persons, not parents or teachers of students at the school, drawn from such groups or entities as municipal government, business and labor organizations, institutions of higher education, human services, agencies or other interested groups, however, that not more than fifty percent of the council shall be non-school members. The principal shall have the responsibility of defining the composition of and forming the group. School councils should be broadly representative of the racial and ethnic diversity of the school building and community.

The school council shall meet regularly with the principal of the school and shall assist in the identification of the educational needs of the students attending the school, in the review of the annual school budget and in the formation of a school improvement plan.

SCHOOL HOURS & CALENDAR

Opening Bell	8:10 A.M.
School in session	8:15 A.M.
First lunch	12:00 P.M.
Second lunch	12:30 P.M.
School day ends	2:30 P.M.

The School Calendar, which is sent home with your child at the beginning of the school year, contains information such as dates of marking periods, distribution of report cards, parent conferences, curriculum days, vacation periods, school hours, etc. By making reference to the calendar many answers to school related questions may be quickly obtained. We also send home a monthly Mapleshade Calendar to keep you informed.

STUDENT RECORDS

Federal Regulations and the Commonwealth of Massachusetts Board of Education Regulations require that all records pertaining to an individual student be made available for inspection by the parents. If you wish to review your child's records, please contact the school for information regarding the procedure to be followed.

PARENT-TEACHER CONFERENCES

Parent-Teacher conferences are regularly scheduled during the year as noted on the school calendar. Parents will receive notification of their specific conference dates and times. Parents are encouraged to call the school at any time and ask about their child's progress. A partnership between parents and teachers results in benefits for the child.

SCHOOL PICTURES

School pictures are taken annually in the Fall. Although every child is photographed, this does not obligate the parents or guardian in any way to make a purchase.

LOST AND FOUND

Articles which have been found in the building or on school grounds are turned in to the office, where they may be claimed by their owners. It is suggested that articles of clothing, lunch boxes

and other personal items labeled with the child's name. This enables us to return lost items to the rightful owner. Losses should be reported and the "Lost and Found" box should be checked periodically whenever losses occur. At midyear, and again at the end of the year, unclaimed clothing is donated to a local shelter.

STUDENT DROP-OFF AND PICK-UP

IMPORTANT NOTE: The main parking lot and fire lane (yellow curbing area) are reserved for busses from 8:00 a.m. to 8:30 a.m. and from 2:00 p.m. to 2:30 p.m. Cars should not enter this area during these times. If a parent needs to drop off or pick up a child between the hours of 8:15 a.m. and 2:30 p.m., they should park their car in the parking lot and sign their child in or out of school.

Parents dropping off students before school and picking up students at the end of the school day should use the drive-thru road. The purpose of the drive-thru is to provide safer conditions for students traveling to and from school by car. However, the safety of each child still depends upon the patience and caution of adults using the drive-thru. Town officials have given considerable time and thought in planning the traffic flow of the drive-thru. There are ample signs and pavement markings clearly indicating how vehicles should proceed through the drive-thru area. There will be staff on duty to assist parents and students in learning the proper procedures. If we all work together, we will improve student safety at Mapleshade.

The following are important guidelines for the use of the drive-thru (refer to the accompanying diagram):

- The drive-thru is designed for ONE-WAY TRAFFIC ONLY. Traffic should flow only from WEST to EAST. All traffic will enter at the point designated "A" on the diagram. This is the end furthest from the school.
- Cars must proceed slowly at all times.
- Cars are not to park on the yellow hashmarks (marked as "B" on the diagram). These hashmarks are found at the beginning and the end of the drive-thru. There is also a 2-foot wide hashmark zone along the adjoining sidewalk. The purpose of this safety zone is to prevent car doors from opening into the side walk area.
- Cars coming into the drive-thru should pull up as far as possible and to the right of the white line indicating the drop-off/pick-up zone. Once the student passengers have been dropped off or picked up, the driver should pull out to the left into the thru-traffic lane. Drivers must be alert to other drivers pulling out and to those already in the thru-traffic lane. It is critical that no one park beyond the point designated "C" on the diagram. The drive-thru narrows near the exit and cars parked beyond "C" will block other cars from exiting.

- Note: The drive-thru area is NOT A PARKING LOT. Drivers must not leave their cars.

Please be aware that teacher supervision before school does not begin until 8:00 a.m. Therefore, no student should be dropped off before 8:00 a.m.

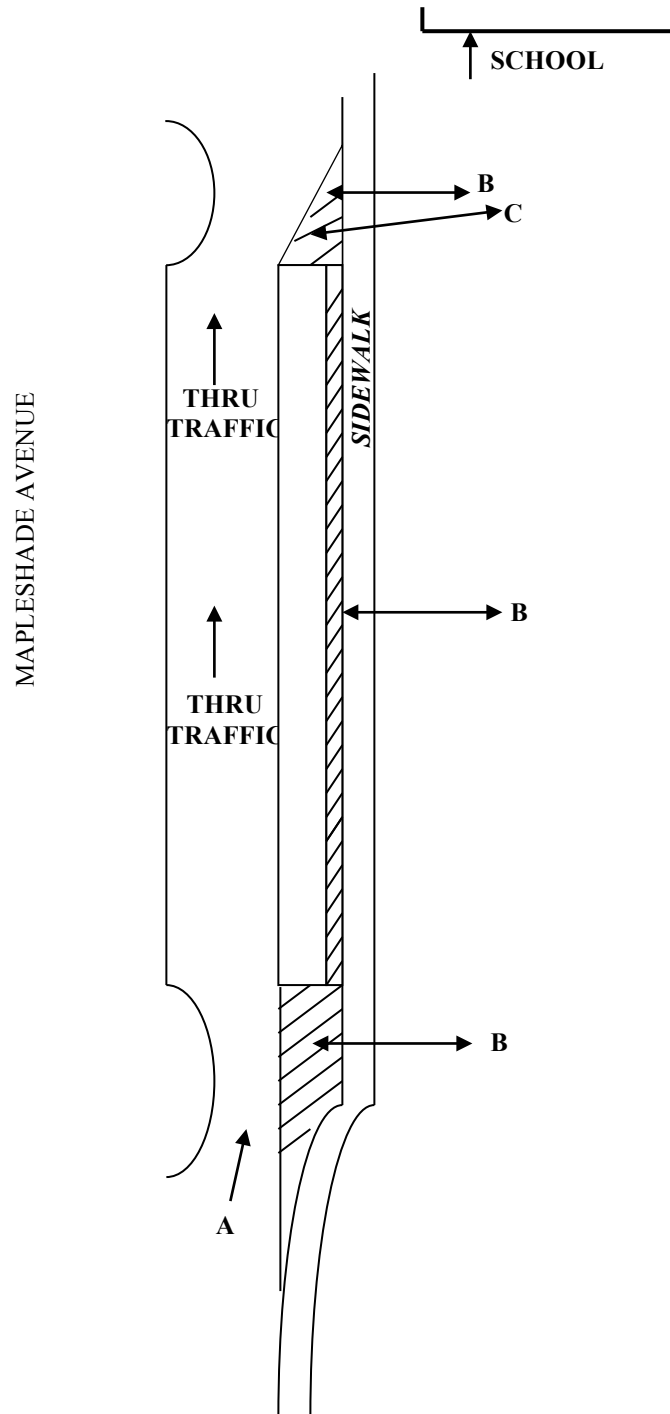

SAFETY AND TRANSPORTATION

Alerting children to the need for being “safety conscious” at all times is a never-ending responsibility. Children should learn the need for rules and recognize the importance of obeying them. The following are safety guidelines to be shared with your child.

A. Walking

1. Walk on sidewalks (no more than two abreast), when they are available.
2. Walk on the left side of the road if there are no sidewalks.
3. Walk in an orderly manner, keeping alert to any dangers. **Do not stop for strangers.**
4. Come directly to school and go directly home.
5. Look in all directions before crossing any street.
6. Cross streets at proper corners.
7. Respect all public and private property.
8. When possible, children should walk home in groups of at least 2 children.

B. Bicycling

1. Use a bicycle helmet and hand signals. This is the law.
2. Never ride two on a bicycle.
3. Keep bicycle under control and in good repair at all times.
4. Look in all directions before crossing a street.
5. Ride your bicycle on the right-hand side of the street.
6. Be careful of walkers and especially automobiles.

C. Bussing

1. Stay out of the street while waiting for the bus.
2. Refrain from pushing or otherwise endangering yourself and friends while waiting at the bus stop.
3. Wait until the bus comes to a full stop before going near it.
4. Take a seat in the bus and remain orderly while the bus is in motion.
5. Keep head, arms and hands inside the bus window.

The school authorities, the bus operators and the police work closely to insure safe operations of all busses. Parental cooperation plays a large part in the success of this phase of the school program. If a pupil's actions are dangerous to himself or the safety of others, the privilege of riding a bus will be withdrawn.

At present, a system of bus warning slips is in operation. When a ticket is issued by a bus driver, it is to be signed by the parent or guardian and then returned to the school office for disposition.

Bus pupils are assigned to a specific bus. Children may not ride a bus other than the one to which they are assigned.

Crossing in front of busses is permitted by State Law. Extreme care must be exercised in crossing. Look both ways and then cross when no vehicles are moving. The East Longmeadow Public Schools specific "Rules of Conduct" on busses will be handed out to each student rider at the beginning of the school year.

SCHOOL CANCELLATIONS OR DELAYED OPENING

It is the policy of the East Longmeadow Public Schools to remain open whenever the buildings are in operating order and the busses can run. In doubtful cases, the final decision whether or not school will be in session is not made until 6:30 a.m. If the decision is to cancel school or delay the starting time, then the local radio stations will carry a "No School" or "Delayed Starting Time" announcement. An automated phone message will also notify families on the primary contact number you have provided the school.

SCHOOL VISITATIONS

In the interest of maintaining good building security, all visitors are requested to stop at the school office upon entering the building. Visitors are also urged to use the designated parking areas and to be conscious of keeping bus loading areas and fire lanes clear of automobiles.

STUDENT ABSENCES

It is the desire of our schools to encourage good school attendance. We also realize that from time to time students are absent for various reasons. Parents are encouraged to call in to report absences. It is always helpful to your child's teacher if a note accompanies your child on his/her return to school following any absence. An automated phone message is sent to confirm absence. The principal will directly contact families, either in writing or request a meeting, for absences or tardiness that is considered "excessive" (5 or more per quarter).

EARLY DISMISSAL

Pupils who are to be dismissed before the end of the school day should bring a written request signed by a parent/guardian. The written request is given to the homeroom teacher and sent to

the office. Only in case of illness or emergency will dismissals be granted during the day without a note from home. Students will be dismissed from the school office to the parent, guardian or a responsible adult designated by the parent.

SCHOOL LUNCHES and BREAKFAST

A well-balanced lunch and breakfast is available at nominal cost. The menus for each month are distributed by the schools and also published on ELPS website. Milk may be purchased by those who bring their own lunches. Lunch and milk are paid for on a daily basis.

We understand that students occasionally forget to bring their cold lunch or hot lunch money to school. We have set up a system where our students may borrow funds for lunch. (Loans are not made for the purchase of ice cream or snacks).

Students are not told that they can't eat breakfast unless we are informed that their your is not to take breakfast. Students that are not identified as free lunch/breakfast students will be billed for breakfast. Please be clear with your child if they are not to have breakfast in school.

As our petty cash box has a limited amount of money, we would appreciate repayment of the lunch loan the following school day. Should any student forget to pay back the loan within **two days**, a reminder will be issued. Should that notice go unanswered, a phone call may be made to inform the parents or guardians of the outstanding debt.

Students are issued a photo identified swipe card to be used as a debit for lunch purchases. These cards are not to leave the cafeteria and are organized by class on a board in the cafeteria. Should you find this card at home please return it to the school ASAP.

If you wish to place money on the card in advance, you may do one of the following:

1. Mail a check payable to the East Longmeadow School Department along with an enclosed self-addressed stamped envelope to: School Lunch Department, 180 Maple Street, East Longmeadow, MA 01028
2. Put a cash amount on the card at Mapleshade Elementary School in the cafeteria daily from 10:30 to 11:35 a.m. or
3. Put a cash amount on the card at the High School lunch office daily from 8:30 a.m. to 2:30 p.m.

SNACKS

Students are allowed to bring a snack to school. We encourage healthy snacks and snacks that don't require multiple containers, packages, utensils, sauces, etc. Children may be required to continue learning and working during snack. Having many different snacks and/or snacks that

are inconvenient to eat may be a distraction during this time. Some easy healthy snacks to consider are fruits and vegetables, granola bars, cheese sticks, crackers, and yogurt.

PUPIL CONDUCT

Establishing and maintaining standards of good conduct for young people are responsibilities mutually shared by the home and school system. Conduct that reflects self-respect and a concern for others is a desirable lifetime goal.

The East Longmeadow Public School's Character Committee has determined that the following character traits should be promoted in all of the activities of the East Longmeadow Public Schools: Kindness, Perseverance, Respect, Responsibility, Caring, Courage, Empathy, Honesty, and Inclusive.

A. Behavior on school grounds

1. Proper playground behavior is SAFE, FAIR PLAY, no pushing, shoving, kicking, tackling or fighting is allowed.
2. Equipment is to be shared fairly among students.
3. All snacks will be eaten on the blacktop area.
4. There should be no sharing of snacks because of allergy concerns.
5. Weather conditions will determine the types of activities available.

B. Behavior during indoor recess

1. Games will be appropriate for indoors.
2. Indoor voices should be used.
3. Students will remain in their homeroom.

C. Building and Classroom behavior

1. Disrespect and/or willful disobedience to a teacher, administrator, or other persons in authority are prohibited.
2. Students will be held responsible for the willful destruction of school property and the personal property of others.
3. The use of offensive language and gestures is prohibited.
4. Fighting and behavior that is threatening to oneself or to the safety of others is prohibited.
5. Smoking is prohibited on school grounds or in the school building.
6. Students will respect everyone's RIGHT TO LEARN and not distract others students in any way.
7. Students will not bring unsafe items to school.
8. Students will walk while inside the school building.
9. Possession of alcoholic beverages, drugs or weapons is prohibited.

D. Dress Code

As per the district Code of Conduct, the following dress code:

1. No exposed undergarments
2. No low-cut shirts
3. No backless, strapless, or one-shoulder shirts/blouses
4. No tops with less than one inch straps
5. No skirts, dresses, and shorts worn shorter than the finger tips when extended at your side.
6. No clothing or accessories containing messages or pictures that disrupt the educational process including those containing vulgarity, or alluding to alcohol, illegal substances, tobacco, etc.
7. Hats or head coverings may be worn for religious purposes. They may not be worn in the building for recreational purposes unless stated otherwise by the Principal.
8. See the *East Longmeadow Code of Conduct* for the complete dress policy.

E. Behavior in the lunchroom - students will:

1. Observe good table manners
2. Stay seated while eating.
3. Use indoor voice.
4. Not throw food or trash on the floor.
5. Wait to be excused to empty trash and trays.
6. Follow the instructions of the lunchroom supervisors at all times.
7. Not go back to the classroom or to the bathroom without adult permission.
8. When dismissed, walk to the playground for recess.

F. Care of textbooks and other school property

1. Damaged and/or lost books are to be paid for by the students or parent.
2. Damages to the building, equipment, and other school property becomes the responsibility of the offending student or parent.

Suspended students have the opportunity to make “academic progress” while serving the suspension. Academic progress includes allowing the student to engage in alternative educational services while suspended.

HOMEWORK POLICY

Regular homework may be assigned but is minimal. A few math problems and reading could be expected. Research suggests that homework does not improve student achievement or responsibility. At times, in addition to regular homework, projects, book reports and study time will also be assigned. Assignments are recorded in students' assignment books, on teacher websites, or on educational communication resources and should be acknowledged by a parent each night.

We suggest that the student have a quiet study place away from family activity. It is encouraging when the parents become involved in school and check over assignments to see that it is completed and ready on time. Refer to Code of Conduct for details.

PROGRESS REPORTING

Report cards are issued on a regularly scheduled basis as indicated on the School Calendar. The report card should be signed by a parent or guardian and returned to the student's teacher.

INSURANCE

A student accident policy is available to all children. Application forms must be signed and returned to the teacher whether they are taking the insurance or not.

STUDENT INFORMATION

The school is not allowed to release for publication, information concerning your child without first obtaining your consent. Examples of the type of information released would be the student's name, class participation in officially recognized activities, and honors and awards. A form requiring your signature related to media, websites, and photographs will be sent home at the beginning of each school year.

SPECIAL SERVICES

Special programs are available for elementary school children who have specific learning and emotional problems standing in the way of learning. Careful evaluations are made by members of the Guidance and Special Services' team to better serve the special needs of the children. Specialists in counseling, speech, reading and special education are involved in the program.

Conduct and Discipline for Students with Disabilities:

All students are expected to meet the requirements for behavior as set forth in this handbook. Chapter 71B of the Massachusetts General Laws, known as Chapter 766, requires that additional provisions be made for students who have been found by an evaluation TEAM to have special needs and whose program is described in an Individual Educational Plan (IEP).

The following requirements apply to the discipline of special needs students:

1. The IEP will indicate whether the student can be expected to meet the regular discipline code. Any modification of the rules set forth in this handbook will be described in the IEP.

In the Event of a Proposed Suspension:

2. The Principal or Head Teacher will notify the Special Education Department Chairman of the suspendable offense of a special needs students and a record will be kept of such notices.
3. When it is known that the suspension of a special needs student will accumulate to ten days in a school year, a review of the IEP as provided in Section 333 of the Chapter 766 Regulations will be held to determine the appropriateness of the student's placement or program. The TEAM will make a finding as to the relationship between the student's misconduct and his/her handicapping condition and either; (a) design a modified program for the student or (b) write an amendment to provide for the delivery of special education services during the suspension and any needed modification of the IEP relative to discipline code expectations.

HEALTH POLICIES

Every effort is made to care for your child's physical, mental and emotional well-being. Sick and injured children are given emergency care but the responsibility for treatment rests with the family.

An "Emergency Information Form" will be sent home to the parents. This form requests information as to the address and place of employment of the parents, the address and telephone number of at least two relatives or close friends who would be willing to care for your child if you are unavailable. It also requests your permission to secure medical attention for your child in case we can't reach you.

Illness and First Aid

Pupils should not come to school when they have a fever and/or vomiting and/or diarrhea. Injuries, skin irritations, etc., which arise outside of school, should be cared for at home or through the family doctor. School related accidents and injuries must be reported to the teacher in charge who will then report them to the school office or nurse.

Administration of Prescribed Medication

The policy for prescribed medication and the forms which must be filled out by parents or guardians and the physician are available from the school nurse.

Every attempt should be made so that medication is given when the child is not in school. We will cooperate in the administration of medication when a chronic or emergency condition exists and medication must be administered in school. To administer medication, the following conditions must be met:

1. There must be on file in the school a written order from the pupil's physician.
2. The pupil's parents and or guardians must submit a completed pertinent data sheet asking that the pupil receive the medication during school hours.
3. The required medication must be kept in a locked cabinet in the school health room and be given by the school nurse or a person designated by the school nurse.
4. The medication shall be issued by a pharmacist whose label on the container shall indicate:
 - a) the name of the child and the prescribing physician.
 - b) the name and strength of the medication.
 - c) the amount of each dose and schedule for administration of the medication.

SCHOOL WEBSITE

<http://mapleshade.eastlongmeadowma.gov/index.html>

We strive to update and maintain our school website on a monthly basis. Some important components to the website are monthly calendars, school year calendars, newsletters, lunch menus, parent resources and information, etc. We are always seeking feedback for information that is not on the website that you would like to see added.

PARENT/GUARDIAN INFORMATION SHARING

The Mapleshade faculty is sensitive to the needs of separated and divorced parents and works to keep them informed about their child's school progress when a separation, divorce, or custody agreement allows for this. All information remains confidential. The school makes efforts to send written, electronic, and telephone communication to both parents and to invite both parents to meetings and events. If for some reason you are not receiving the needed information please don't hesitate to contact the school.

COMMUNICATION

We encourage parents to communicate with the staff about problems and work together to come to a resolution. When a concern arises we ask the parents to keep the following procedure in mind:

1. **Whenever possible, concerns should be dealt with through the classroom teacher.**
2. If a satisfactory resolution is not obtained, parents should bring the issue up with the principal.
3. If further work on the issue is necessary, the next step would be to see the superintendent of schools.

4. Finally, the school committee would be contacted if a resolution still hasn't been accomplished.

CURRICULUM AND ACADEMICS

ENGLISH LANGUAGE ARTS

Our language arts curriculum strives to ensure that all students develop into confident readers, writers and communicators with critical and creative thinking abilities. Children will actively write, read, discuss and debate across all content areas and genres. Students are instructed at their reading and writing abilities and challenged at and beyond their learning frontier during whole class and small group instruction. Our spelling curriculum encourages the study of word structures and meanings. Spelling is not merely the memorization of words. It involves a variety of strategies that will enable students to attempt difficult words that they wish to spell and become conventional spellers. The study of vocabulary in text and grammar in reading and writing are also instructed.

MATHEMATICS

Our mathematics curriculum aims to empower all students to develop into mathematical thinkers and problem solvers. Students are encouraged to use estimation, mental mathematics, paper and pencil, calculators, manipulatives, and peer collaboration to problem-solve. They learn to compute numbers fluently, apply strategies, algorithms, and explain verbally or in writing why their strategy worked to solve a particular problem. Students are encouraged to use mathematical language and also to use and/or invent models to explain their thinking. New materials, tools, games and strategies are introduced and reinforced to prepare students for the future. Multiple strategies and solutions are encouraged, thereby broadening the understanding of problem solving as well as appreciating a broader range of learning styles. Students explore mathematical problems in depth, work together, use a variety of concrete materials, and appropriate technologies.

SCIENCE

The science curriculum encourages investigations, observations and experiments in life, earth, space and physical sciences. Skills of inquiry, observation, collaboration and the scientific and engineering practices are used in each grade, similar to what professional scientists and engineers do in the field. Our goal is for students to develop scientific thinking by making observations, planning, investigating, experimenting, engineering, problem solving, and use of technology.

HISTORY/ SOCIAL STUDIES

Our social studies curriculum is embedded in our literacy instruction and explores concepts and questions in civics, government, Massachusetts, US and World history, North American and world geography, Egypt, Africa and economics.

ENRICHMENT/GIFTED AND TALENTED PROGRAM

The GT/Enrichment Program at Mapleshade Elementary School includes two main components. The first component is the “Push-In” component, where the teacher visits every class once a week to provide students with rigorous learning experiences that focus on developing students’ creativity, problem-solving, and collaboration skills. The Push-In portion of the program aims to both support and extend beyond the curriculum and the common core standards. The second part of the program is called the “Pull-out” component. This component of the program allows the teacher to work with small groups of students who have been carefully identified to have specific strengths in the areas of Reading/ELA or Mathematics. The main purpose of this component is to provide an opportunity for strong and talented students to work with their peers on challenging, independent work that extends their thinking beyond the regular classroom.

STUDENT ASSESSMENTS

In addition to state mandated MCAS, the students are assessed two to three times per year in the following areas utilizing the following evidence-based assessments:

Reading Level – Fountas and Pinnell Benchmark Assessment

Reading Ability – STAR Assessments

Math Ability – STAR Assessments

Ability to write in response to reading – District Based Assessment

Ability to express mathematical thinking – District Based Assessment

This assessment data is made available during parent-teacher conferences and through an online secure portal for STAR Assessments. We encourage all parents to ask their child’s teachers about these assessments and their importance for instructional and educational decisions.

ASSISTING CHILDREN AND TEACHER TEAM (ACT)

Mapleshade School has a process in place to document student learning and meet as professionals when a child’s academic progress, social development, emotional safety, and/or behaviors pose challenges. This process is in place for a few reasons: Primarily, we care about all of our students and strive to accommodate their needs and adapt to their learning styles. To do this well we seek the advice of our colleagues from a range of skillsets and backgrounds. Secondly, we establish intervention plans and measure their progress over a period of time specific to the agreed upon changes that took place during the meeting. Lastly, we are mandated to exhaust all our possible resources, strategies, and interventions before referring a child for special education evaluations. We communicate our decisions with parents and work together to be the best we can be for our students.

**PLEASE SEE THE ENTIRE CODE OF CONDUCT
Rules of Conduct AND ACCEPTABLE INTERNET USE POLICY
contained in the E.L.P.S. CODE OF CONDUCT
in addition to this handbook.**

**You must sign that you have read the E.L.P.S. Code of Conduct
and discussed it with your child.**

Thank you for your cooperation in keeping the children of East Longmeadow safe. Working together we will provide a safe, high-quality learning environment for all of our children.